

Random Matrices with Blocks of Intermediate Scale
Strongly Correlated Band Matrices

Jiayi Tong

Advisor: Dr. Todd Kemp

May 30, 2017
Department of Mathematics
University of California, San Diego

Contents

| | | |
|----------|--------------------------------|----------|
| 1 | Introduction | 2 |
| 2 | Notation and Background | 6 |
| 2.1 | Band Matrix | 6 |
| 2.2 | Wick's Theorem | 6 |
| 3 | Models | 8 |
| 3.1 | Model | 8 |
| 3.2 | Proof | 17 |

1 Introduction

A random matrix is simply a matrix, all of whose entries are random. This means that X is an $n \times n$ matrix with entries X_{ij} ($1 \leq i, j \leq n$) that are random variables.

The eigenvalues of symmetric matrices with random independent entries are well-understood.

In the 1950s, Wigner's semicircle law was first observed by Eugene Wigner [4].

Definition 1. Let $\{Y_{i,j}\}_{1 \leq i \leq j}$ and we assume

- $\{Y_{i,j}\}_{1 \leq i \leq j}$ are independent
- The diagonal entries $\{Y_{i,i}\}_{1 \leq i}$ are identically-distributed, and the off-diagonal entries $\{Y_{i,j}\}_{1 < i < j}$ are identically-distributed.
- $\mathbb{E}[Y_{ij}^2] < \infty$ for all i, j

Let

$$[\mathbf{Y}_n]_{ij} = \begin{cases} Y_{ij}, & i \leq j \\ Y_{ji}, & i > j \end{cases}$$

With $\mathbb{E}[Y_{12}^2] > 0$, then the matrices $\mathbf{X}_n = n^{-1/2}\mathbf{Y}_n$ are **Wigner matrices**.

No matter what distribution the entries of Wigner matrix have, the density of eigenvalues converges to a universal distribution, known as Wigner's semicircle law:

$$\sigma_t(dx) = \frac{1}{2\pi t} \sqrt{(4t - x^2)_+} dx$$

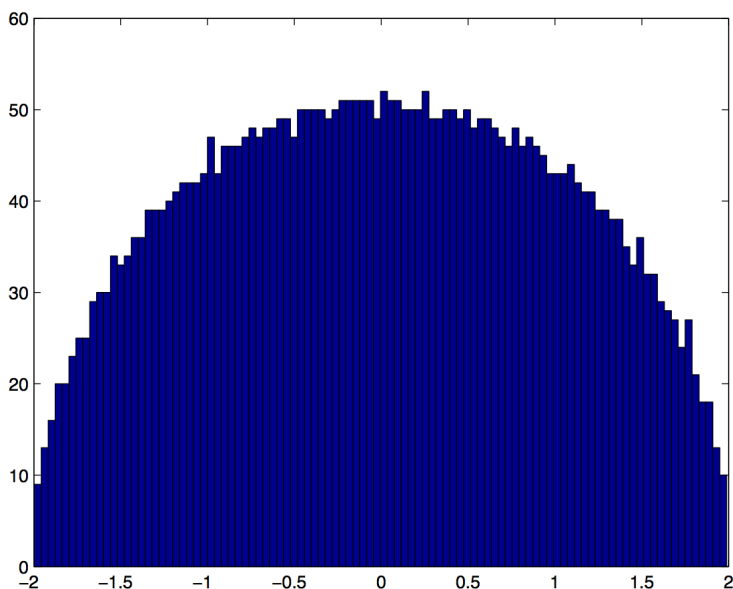

Figure 1: The density of eigenvalues of an instance of X_{4000} , a Gaussian Wigner matrix.

However, when the entries of the random matrix are correlated, few things are well-understood by now. Therefore, in this paper, our aim is to study the empirical eigenvalue distribution of square random models with some structured correlations. To be more specific, we study the eigenvalue distribution of band matrices whose bands on diagonals are independent of each other, but the identically distributed entries along each band are correlated.

The asymptotic empirical eigenvalue distribution can be understood by considering the limits of the matrix moments in expectation:

$$\lim_{n \rightarrow \infty} \frac{1}{n} \mathbb{E} \text{Tr}[X^k]$$

where $k \in \mathbb{N}$.

Why do these matrix moments relate to the eigenvalue distribution? First, we need to understand what a histogram is.

There are some data points $\lambda_1, \lambda_2, \dots, \lambda_n$. These data points need to be put into some “bins” or intervals, and the number of the points in each bin should be counted so that we could know the heights of the bins.

For example, in the interval $[a, b]$, we need to count

$$\# \{j \in \{1, \dots, n\} : \lambda_j \in [a, b]\}$$

We can use the indicator function $\mathbb{1}_{[a,b]}$. It is defined by

$$\mathbb{1}_{[a,b]}(x) = \begin{cases} 1, & \text{if } a \leq x \leq b \\ 0, & \text{otherwise} \end{cases}$$

To get the desired count, we need to add all indicator functions up as follows:

$$\# \{j \in \{1, \dots, n\} : \lambda_j \in [a, b]\} = \mathbb{1}_{[a,b]}(\lambda_1) + \mathbb{1}_{[a,b]}(\lambda_2) + \dots + \mathbb{1}_{[a,b]}(\lambda_n)$$

Now, we have the height of interval $[a, b]$. To get the whole histogram, we should compute the random variables:

$$C_{[a,b]} := \sum_{j=1}^n \mathbb{1}_{[a,b]}(\lambda_j)$$

for all a, b . Since the λ_j are eigenvalues of a random matrix, it is very hard to compute them exactly. Therefore, we approximate the function $C_{[a,b]}$ by a sequence of polynomials P_m . As the degree of polynomials becomes higher and higher, we can find a sequence of polynomials with $P_m(x) \rightarrow \mathbb{1}_{[a,b]}(x)$ for every x .

Then, we have

$$C_{[a,b]} := \sum_{j=1}^n \mathbb{1}_{[a,b]}(\lambda_j) = \lim_{m \rightarrow \infty} \sum_{j=1}^n P_m(\lambda_j)$$

To get $C_{[a,b]}$, we need to compute

$$\sum_{j=1}^n P(\lambda_j)$$

for every polynomial $P(x) = a_0 + a_1x + a_2x^2 + \dots + a_kx^k$ for some real numbers a_0, a_1, \dots, a_k . Then

$$\begin{aligned} \sum_{j=1}^n P(\lambda_j) &= \sum_{j=1}^n (a_0 + a_1\lambda_j + a_2\lambda_j^2 + \dots + a_k\lambda_j^k) \\ &= na_0 + a_1 \sum_{j=1}^n \lambda_j + a_2 \sum_{j=1}^n \lambda_j^2 + \dots + a_k \sum_{j=1}^n \lambda_j^k \end{aligned}$$

So we need to know

$$\sum_{j=1}^n \lambda_j^k$$

for each moment k .

Now, we have X , a $n \times n$ symmetric random matrix. It is orthogonally diagonalizable:

$$X = QDQ^{-1}$$

where Q is the eigenvector matrix and D is diagonal with the eigenvalues on the diagonal:

$$D = \begin{bmatrix} \lambda_1 & 0 & \dots & 0 \\ 0 & \lambda_2 & \dots & 0 \\ 0 & 0 & \ddots & 0 \\ 0 & 0 & \dots & \lambda_n \end{bmatrix}$$

Then,

$$X^k = QD^kQ^{-1} = Q \begin{bmatrix} \lambda_1^k & 0 & \dots & 0 \\ 0 & \lambda_2^k & \dots & 0 \\ 0 & 0 & \ddots & 0 \\ 0 & 0 & \dots & \lambda_n^k \end{bmatrix} Q^{-1}$$

And thus,

$$\text{Tr}(X^k) = \text{Tr}(QD^kQ^{-1}) = \text{Tr}(Q^{-1}QD^k) = \text{Tr}(D^k)$$

since $Tr(AB) = Tr(BA)$ in general. Hence,

$$Tr(X^k) = Tr \begin{bmatrix} \lambda_1^k & 0 & \dots & 0 \\ 0 & \lambda_2^k & \dots & 0 \\ 0 & 0 & \dots & 0 \\ 0 & 0 & \dots & \lambda_n^k \end{bmatrix} = \sum_{j=1}^n \lambda_j^k$$

Therefore, if we know the matrix moments:

$$Tr(X^k)$$

for each integer k , then we know the quantities $\sum_{j=1}^n \lambda_j^k$, so we know all quantities $\sum_{j=1}^n P(\lambda_j)$ for polynomials P . Then we are able to approximate the height of each bin or interval $[a,b]$ as closely as we need.

Since X is a random matrix with random variables as entries in our model, we cannot compute $Tr(X^k)$ exactly. However,

$$\mathbb{E}Tr[X^k]$$

can be computed exactly in our model. Then we can prove that $\text{Var}(Tr(X^k))$ is small as matrix size $n \rightarrow \infty$. The variance calculation is done in the paper [2]. So we really do know the limit shape of the histogram by computing

$$\frac{1}{n} \mathbb{E}Tr[X^k]$$

after normalization.

We know that

$$Tr(X^k) = \sum_{i_1, i_2, i_3, \dots, i_k=1}^n X_{i_1 i_2} X_{i_2 i_3} X_{i_3 i_4} \dots X_{i_k i_1} \quad (1)$$

take expectation of both sides of equation (1), then

$$\mathbb{E}Tr(X^k) = \sum_{i_1, i_2, i_3, \dots, i_k=1}^n \mathbb{E}[X_{i_1 i_2} X_{i_2 i_3} X_{i_3 i_4} \dots X_{i_k i_1}] \quad (2)$$

In this paper, we will first define the **maximally correlated band random matrix** which we work on, and then give the proof that the limits of this matrix moments in expectation are the moments of Gaussian.

2 Notation and Background

2.1 Band Matrix

In order to guarantee that the matrix has real eigenvalues, we will make the assumption that X is a symmetric $n \times n$ matrix, i.e. $X_{ij} = X_{ji}$, where $1 \leq i, j \leq n$. Let $[Y_m]$ be a sequence of random variables, where $0 \leq m \leq n - 1$.

Definition 2. Define a $n \times n$ matrix with entries

$$X_{i,i+m} = X_{i,i-m} = \frac{1}{\sqrt{n}} Y_m$$

as a *random band matrix*, which have the following form:

$$\begin{bmatrix} X_{1,1} & X_{1,2} & \dots & \dots & \dots & X_{1,n} \\ X_{1,2} & X_{2,2} & \dots & \dots & \dots & X_{2,n} \\ \dots & \dots & \dots & \dots & X_{i,i+m} & \dots \\ \vdots & \vdots & \vdots & \vdots & \vdots & \vdots \\ \dots & \dots & X_{i,i+m} & \dots & \dots & \dots \\ X_{1,n} & X_{2,n} & \dots & \dots & \dots & X_{n,n} \end{bmatrix}$$

is equivalent to

$$\frac{1}{\sqrt{n}} \begin{bmatrix} Y_0 & Y_1 & \dots & \dots & \dots & Y_{n-1} \\ Y_1 & Y_0 & \dots & \dots & Y_m & Y_{n-2} \\ \dots & \dots & \dots & \dots & \dots & \dots \\ \vdots & \vdots & \vdots & \vdots & \vdots & \vdots \\ \dots & Y_m & \dots & \dots & \dots & \dots \\ Y_{n-1} & Y_{n-2} & \dots & \dots & \dots & Y_0 \end{bmatrix}$$

We call this matrix: **maximally correlated band matrix**.

The maximally correlated band matrix is given the following assumptions:

- Entries Y_m are independent of each other.
- Entries Y_m on the diagonals are identically-distributed standard normal random variables.

2.2 Wick's Theorem

To calculate the limiting matrix moments in expectation, we apply Wick's Theorem.

Wick's theorem is a method of reducing high-order moments to combinatorial expressions involving only covariances of Gaussian random variables. It is used for the formula expressing the higher moments of a Gaussian distribution in terms of the second moments.

Definition 3. Define $\mathcal{P}_2(2k)$ as all pairings of $\{1, 2, \dots, 2k\}$. Let π be one of the $2k$ integers' possible pairings in \mathcal{P}_2 ,

$$\pi = \{\{\alpha_1, \beta_1\}, \{\alpha_2, \beta_2\}, \dots, \{\alpha_k, \beta_k\}\}$$

Note that

$$\#\{\mathcal{P}_2(2k)\} = (2k - 1)!! = (2k - 1)(2k - 3)(2k - 5) \dots (5)(3)(1)$$

Theorem 1. *Wick's Theorem*

Let X_1, X_2, \dots, X_{2k} be jointly independent normal random variables. Then

$$\mathbb{E}[X_1 X_2 \dots X_{2k}] = \sum_{\pi \in \mathcal{P}_2(2k)} \prod_{\{\alpha, \beta\} \in \pi} \mathbb{E}[X_\alpha X_\beta]$$

Example 2.1. when $k = 4$, $i_1, i_2, i_3, i_4 \in \{1, n\}$ and X_{ij} are the entries of a matrix, then according to equation (2):

$$\mathbb{E}Tr(X^4) = \sum_{i_1, i_2, i_3, i_4}^n \mathbb{E}[X_{i_1 i_2} X_{i_2 i_3} X_{i_3 i_4} X_{i_4 i_1}]$$

where by Wick's theorem

$$\begin{aligned} & \mathbb{E}[X_{i_1 i_2} X_{i_2 i_3} X_{i_3 i_4} X_{i_4 i_1}] \\ &= \mathbb{E}[X_{i_1 i_2} X_{i_2 i_3}] \mathbb{E}[X_{i_3 i_4} X_{i_4 i_1}] + \mathbb{E}[X_{i_1 i_2} X_{i_3 i_4}] \mathbb{E}[X_{i_2 i_3} X_{i_4 i_1}] + \mathbb{E}[X_{i_1 i_2} X_{i_4 i_1}] \mathbb{E}[X_{i_2 i_3} X_{i_3 i_4}] \end{aligned} \quad (3)$$

Three pairings of four variables can be expressed graphically.

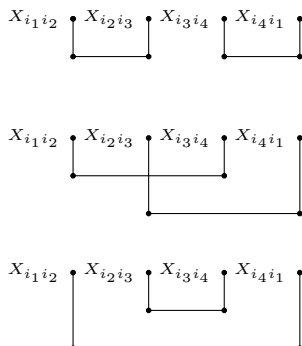

In conclusion, by Wick's Theorem, we can express the convergence of matrix moments in expectation as follows:

$$\begin{aligned} \frac{1}{n} \mathbb{E} \text{Tr}[X^{2k}] &= \frac{1}{n} \sum_{i_1, \dots, i_{2k}=1}^n \mathbb{E}[X_{i_1, i_2} X_{i_2, i_3} \dots X_{i_{2k}, i_1}] \\ &= \frac{1}{n} \sum_{i_1, \dots, i_{2k}=1}^n \sum_{\pi \in \mathcal{P}_2(2k)} \prod_{\{\alpha, \beta\} \in \pi} \mathbb{E}[X_{i_\alpha, i_{\alpha+1}} X_{i_\beta, i_{\beta+1}}] \end{aligned} \quad (4)$$

3 Models

In this section, we will study the empirical eigenvalue distribution by applying specific random variables into the band matrices.

3.1 Model

Here is a histogram of the eigenvalues of a 4000×4000 matrix sampled from the maximally correlated band model (Definition 2) with Gaussian entries:

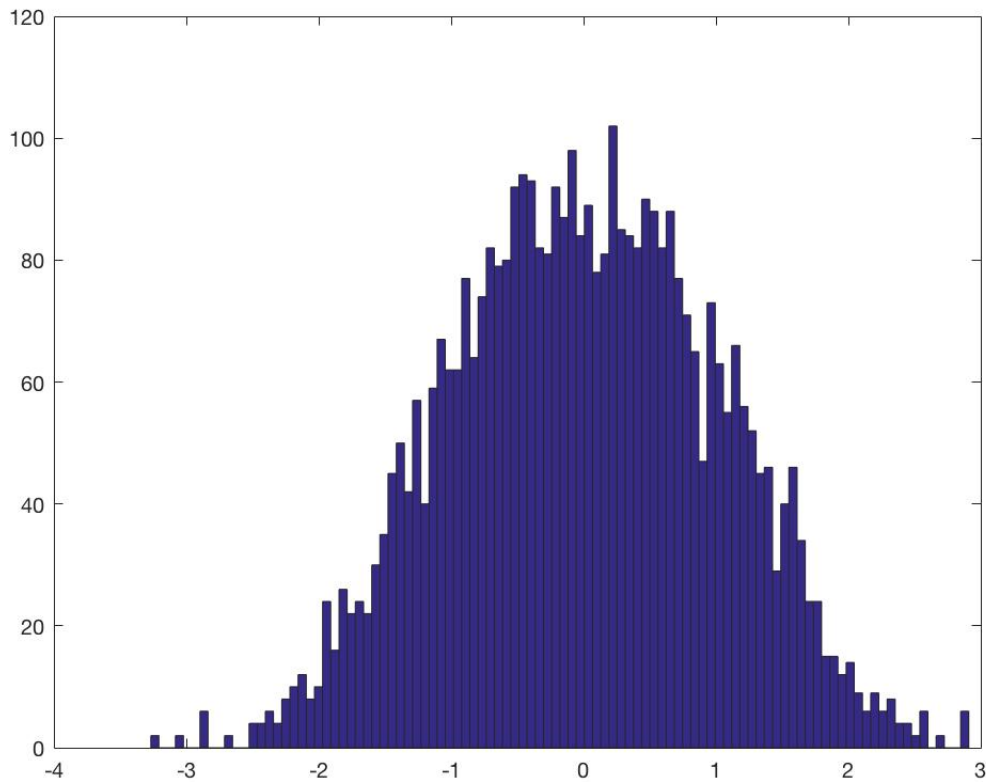

Figure 2: The density of eigenvalues of an instance of X_{4000} , a Gaussian band matrix.

Theorem 2 (Kemp, Tong, 2017). *Let X_n be a maximally correlated band matrix according to Definition 2. The limit matrix moments are the moments*

of a Gaussian distribution:

$$\lim_{n \rightarrow \infty} \frac{1}{n} \mathbb{E} \text{Tr}[X^k] = \begin{cases} 0, & k \text{ odd} \\ (k-1)!!, & k \text{ even} \end{cases}$$

where $k = 1, 2, 3, \dots$

The full proof of this theorem will be presented in Section 3.2.

Before the proof, some propositions are needed.

Proposition 1. Let X be a maximally correlated band matrix, where $X_{i,i+m} = X_{i,i-m} = \frac{1}{\sqrt{n}} Y_m$. Let $\{\alpha, \beta\}$ be a block in pairing

$$\pi = \{\{\alpha, \beta\}, \{\alpha_2, \beta_2\}, \dots, \{\alpha_k, \beta_k\}\}$$

Because of the independence of entries, term $\mathbb{E}[X_{i_\alpha, i_{\alpha+1}} X_{i_\beta, i_{\beta+1}}]$ in equation (3) does not equal to zero if and only if

$$|i_\alpha - i_{\alpha+1}| = |i_\beta - i_{\beta+1}|$$

Proof. If

$$|i_\alpha - i_{\alpha+1}| \neq |i_\beta - i_{\beta+1}|$$

then

$$\begin{aligned} \mathbb{E}[X_{i_\alpha, i_{\alpha+1}} X_{i_\beta, i_{\beta+1}}] &= \mathbb{E}[X_{i_\alpha, i_{\alpha+1}}] \mathbb{E}[X_{i_\beta, i_{\beta+1}}] \\ &= \frac{1}{\sqrt{n}} \cdot \frac{1}{\sqrt{n}} \cdot \mathbb{E}[Y_{|i_\alpha - i_{\alpha+1}|}] \mathbb{E}[Y_{|i_\beta - i_{\beta+1}|}] \\ &= \frac{1}{n} \cdot 0 \cdot 0 \\ &= 0 \end{aligned}$$

□

Therefore, to get a non-zero $\mathbb{E}[X_{i_\alpha, i_{\alpha+1}} X_{i_\beta, i_{\beta+1}}]$, there are two cases of the indices:

- Positive case: $i_\alpha - i_{\alpha+1} = i_\beta - i_{\beta+1}$
- Negative case: $i_\alpha - i_{\alpha+1} = i_{\beta+1} - i_\beta$

Proposition 2. Only the pairings of the indices which are under the negative case:

$$i_\alpha - i_{\alpha+1} = i_{\beta+1} - i_\beta$$

contribute to leading order of the results in Theorem 3.

The proof of this proposition will be presented in Section 3.2. Before proving the general k -th moment, a specific example with $k = 4$ will be explained first.

Example 3.1. When $k = 4$, there are four indices: $i_1, i_2, i_3, i_4 \in \{1, n\}$. The matrix moment's expectation can be expressed as:

$$\frac{1}{n} \mathbb{E} \text{Tr}[X^4] \tag{5}$$

$$= \frac{1}{n} \sum_{i_1, i_2, i_3, i_4=1}^n \mathbb{E}[X_{i_1 i_2} X_{i_2 i_3} X_{i_3 i_4} X_{i_4 i_1}] \tag{6}$$

$$= \frac{1}{n} \sum_{i_1, \dots, i_{2k}=1}^n (\mathbb{E}[X_{i_1 i_2} X_{i_2 i_3}] \mathbb{E}[X_{i_3 i_4} X_{i_4 i_1}] + \mathbb{E}[X_{i_1 i_2} X_{i_3 i_4}] \mathbb{E}[X_{i_2 i_3} X_{i_4 i_1}] + \mathbb{E}[X_{i_1 i_2} X_{i_4 i_1}] \mathbb{E}[X_{i_2 i_3} X_{i_3 i_4}]) \tag{7}$$

Then, from the proposition 1, we see that there are four cases of these four indices:

- Case I:

$$\begin{aligned} &\text{If } |i_1 - i_2| = |i_2 - i_3| = |i_3 - i_4| = |i_4 - i_1|, \\ &\text{then, } \mathbb{E}[X_{i_1 i_2} X_{i_2 i_3}] \mathbb{E}[X_{i_3 i_4} X_{i_4 i_1}] \neq 0, \mathbb{E}[X_{i_1 i_2} X_{i_3 i_4}] \mathbb{E}[X_{i_2 i_3} X_{i_4 i_1}] \neq 0, \\ &\mathbb{E}[X_{i_1 i_2} X_{i_4 i_1}] \mathbb{E}[X_{i_2 i_3} X_{i_3 i_4}] \neq 0 \end{aligned}$$

- Case II:

$$\begin{aligned} &\text{If } |i_1 - i_2| = |i_2 - i_3| \neq |i_3 - i_4| = |i_4 - i_1|, \\ &\text{then, } \mathbb{E}[X_{i_1 i_2} X_{i_2 i_3}] \mathbb{E}[X_{i_3 i_4} X_{i_4 i_1}] \neq 0, \mathbb{E}[X_{i_1 i_2} X_{i_3 i_4}] \mathbb{E}[X_{i_2 i_3} X_{i_4 i_1}] = 0, \\ &\mathbb{E}[X_{i_1 i_2} X_{i_4 i_1}] \mathbb{E}[X_{i_2 i_3} X_{i_3 i_4}] = 0 \end{aligned}$$

- Case III:

$$\begin{aligned} &\text{If } |i_1 - i_2| = |i_3 - i_4| \neq |i_2 - i_3| = |i_4 - i_1|, \\ &\text{then, } \mathbb{E}[X_{i_1 i_2} X_{i_2 i_3}] \mathbb{E}[X_{i_3 i_4} X_{i_4 i_1}] = 0, \mathbb{E}[X_{i_1 i_2} X_{i_3 i_4}] \mathbb{E}[X_{i_2 i_3} X_{i_4 i_1}] \neq 0, \\ &\mathbb{E}[X_{i_1 i_2} X_{i_4 i_1}] \mathbb{E}[X_{i_2 i_3} X_{i_3 i_4}] = 0 \end{aligned}$$

- Case IV:

$$\begin{aligned} &\text{If } |i_1 - i_2| = |i_4 - i_1| \neq |i_2 - i_3| = |i_3 - i_4|, \\ &\text{then, } \mathbb{E}[X_{i_1 i_2} X_{i_2 i_3}] \mathbb{E}[X_{i_3 i_4} X_{i_4 i_1}] \neq 0, \mathbb{E}[X_{i_1 i_2} X_{i_3 i_4}] \mathbb{E}[X_{i_2 i_3} X_{i_4 i_1}] = 0, \\ &\mathbb{E}[X_{i_1 i_2} X_{i_4 i_1}] \mathbb{E}[X_{i_2 i_3} X_{i_3 i_4}] \neq 0 \end{aligned}$$

To calculate the large- n limit of equation (7), we discuss each case separately and then sum them up to get the leading term of the limit.

Case I:

$$|i_1 - i_2| = |i_2 - i_3| = |i_3 - i_4| = |i_4 - i_1| = m$$

where $m = 0, 1, 2, \dots, n - 1$

Under this case, equation (7) can be expressed as:

$$\begin{aligned}
& \frac{1}{n} \sum_{i_1, \dots, i_4=1}^n \mathbb{E}[X_{i_1 i_2} X_{i_2 i_3}] \mathbb{E}[X_{i_3 i_4} X_{i_4 i_1}] + \mathbb{E}[X_{i_1 i_2} X_{i_3 i_4}] \mathbb{E}[X_{i_2 i_3} X_{i_4 i_1}] \\
& + \mathbb{E}[X_{i_1 i_2} X_{i_4 i_1}] \mathbb{E}[X_{i_2 i_3} X_{i_3 i_4}] \\
& = \frac{1}{n} \cdot \sum_{m=0}^{n-1} \left(\frac{1}{n} \cdot \frac{1}{n} \cdot \mathbb{E}[Y_m^2]^2 + \frac{1}{n} \cdot \frac{1}{n} \cdot \mathbb{E}[Y_m^2]^2 + \frac{1}{n} \cdot \frac{1}{n} \cdot \mathbb{E}[Y_m^2]^2 \right) \\
& = 3 \cdot \frac{1}{n} \cdot \frac{1}{n^2} \cdot \sum_{m=0}^{n-1} \mathbb{E}[Y_m^2]^2 \\
& = 3 \cdot \frac{1}{n} \cdot \frac{1}{n^2} \cdot O(n^2) \\
& = O\left(\frac{1}{n}\right)
\end{aligned} \tag{8}$$

As $n \rightarrow \infty$, $O\left(\frac{1}{n}\right) \rightarrow 0$. Therefore, this case does not contribute to the leading term of the convergence.

Case II:

$$|i_1 - i_2| = |i_2 - i_3| \neq |i_3 - i_4| = |i_4 - i_1|$$

We change the absolute value into positive and negative cases:

$$i_1 - i_2 = \pm(i_2 - i_3) \neq i_3 - i_4 = \pm(i_4 - i_1)$$

The reason why we do this change is that we want to convert the relation between the indices into a system of equations. Then we now reduce the matrices which consist of the coefficients of the system to get the rank or nullity of the matrices. This value will give us the leading order under each case, so that we can tell the indices under which case will contribute to the leading term in the limit.

There are three possible subcases:

II.1: (both equations are with positive sign)

$$\begin{cases} i_1 - i_2 = +(i_2 - i_3) \\ i_3 - i_4 = +(i_4 - i_1) \end{cases}$$

II.2: (one of equations is with positive sign)

$$\begin{cases} i_1 - i_2 = +(i_2 - i_3) \\ i_3 - i_4 = -(i_4 - i_1) \end{cases}$$

or

$$\begin{cases} i_1 - i_2 = -(i_2 - i_3) \\ i_3 - i_4 = +(i_4 - i_1) \end{cases}$$

The reason these two cases are put together is that there are only two rows in the coefficients matrices, where one matrix can be acquired by changing the order of another matrix's row.

II.3: (both equations are with negative sign)

$$\begin{cases} i_1 - i_2 = -(i_2 - i_3) \\ i_3 - i_4 = -(i_4 - i_1) \end{cases}$$

Then, we convert the system of equations into coefficient matrices and solve the rank or nullity of the matrices.

II.1: :

Moving all the terms to the left side of the equation, we have the following matrix equation:

$$\begin{bmatrix} 1 & -2 & 1 & 0 \\ 1 & 0 & 1 & -2 \end{bmatrix} \begin{bmatrix} i_1 \\ i_2 \\ i_3 \\ i_4 \end{bmatrix} = \begin{bmatrix} 0 \\ 0 \end{bmatrix}$$

Then, we have the coefficient matrix:

$$\begin{bmatrix} 1 & -2 & 1 & 0 \\ 1 & 0 & 1 & -2 \end{bmatrix}$$

By reduction and calculation, the rank is 2 and nullity is $4 - 2 = 2$.

The nullity of the matrix gives us the dimension of the null space, then we have the number of solutions. When we have the order of number of the solutions, we can justify whether the case contribute to the limit's leading term to prove proposition 2.

II.2: :

Similarly, we have

$$\begin{bmatrix} 1 & 0 & -1 & 0 \\ 1 & 0 & -2 & 1 \end{bmatrix} \begin{bmatrix} i_1 \\ i_2 \\ i_3 \\ i_4 \end{bmatrix} = \begin{bmatrix} 0 \\ 0 \end{bmatrix}$$

The coefficient matrix is:

$$\begin{bmatrix} 1 & 0 & -1 & 0 \\ 1 & 0 & -2 & 1 \end{bmatrix}$$

whose rank is 2 and nullity is $4 - 2 = 2$.

II.3: :

In this case, i_2 and i_4 are canceled in the equation, it gives $i_1 = i_3$.

$$\begin{bmatrix} 1 & 0 & -1 & 0 \\ 1 & 0 & -1 & 0 \end{bmatrix} \begin{bmatrix} i_1 \\ i_2 \\ i_3 \\ i_4 \end{bmatrix} = \begin{bmatrix} 0 \\ 0 \end{bmatrix}$$

Therefore, we have three free parameters:

$$i_1, i_2, i_4$$

The nullity of the coefficient matrix is **3**.

Under this case, because of the property of i.i.d random variables,

$$\mathbb{E}[X_{i_1 i_2} X_{i_3 i_4}] \mathbb{E}[X_{i_2 i_3} X_{i_4 i_1}] = \mathbb{E}[X_{i_1 i_2}] \mathbb{E}[X_{i_2 i_3}] \mathbb{E}[X_{i_3 i_4}] \mathbb{E}[X_{i_4 i_1}] = 0$$

and

$$\mathbb{E}[X_{i_1 i_2} X_{i_4 i_1}] \mathbb{E}[X_{i_2 i_3} X_{i_3 i_4}] = \mathbb{E}[X_{i_1 i_2}] \mathbb{E}[X_{i_2 i_3}] \mathbb{E}[X_{i_3 i_4}] \mathbb{E}[X_{i_4 i_1}] = 0$$

Then, equation (7) can be expressed as:

$$\begin{aligned} & \frac{1}{n} \sum_{i_1, \dots, i_4=1}^n \mathbb{E}[X_{i_1 i_2} X_{i_2 i_3}] \mathbb{E}[X_{i_3 i_4} X_{i_4 i_1}] + \mathbb{E}[X_{i_1 i_2} X_{i_3 i_4}] \mathbb{E}[X_{i_2 i_3} X_{i_4 i_1}] \\ & + \mathbb{E}[X_{i_1 i_2} X_{i_4 i_1}] \mathbb{E}[X_{i_2 i_3} X_{i_3 i_4}] \\ & = \frac{1}{n} \cdot \sum_{m=0}^{n-1} \left(\frac{1}{n} \cdot \frac{1}{n} \cdot \mathbb{E}[Y_m^2]^2 + 0 + 0 \right) \\ & = \frac{1}{n} \cdot \frac{1}{n^2} \cdot \sum_{m=0}^{n-1} \mathbb{E}[Y_m^2]^2 \\ & = \frac{1}{n} \cdot \frac{1}{n^2} \cdot (O(n^3) + O(n^2)) \\ & = 1 + O\left(\frac{1}{n}\right) \end{aligned} \tag{9}$$

Only in II.3, the nullity of the coefficient matrix is **3**. This case gives $O(n^3)$ in the calculation above. As $n \rightarrow \infty$, $O\left(\frac{1}{n}\right) \rightarrow 0$. The leading term is contributed by the II.3, under which, both of the coefficient equations are

using the negative sign.

Case III:

$$|i_1 - i_2| = |i_3 - i_4| \neq |i_2 - i_3| = |i_4 - i_1|$$

We change the absolute value into positive and negative cases:

$$i_1 - i_2 = \pm(i_3 - i_4) \neq i_2 - i_3 = \pm(i_4 - i_1)$$

There are three possible subcases as well:

III.1: (both equations are with positive sign)

$$\begin{cases} i_1 - i_2 = +(i_3 - i_4) \\ i_2 - i_3 = +(i_4 - i_1) \end{cases}$$

III.2: (one of equations is with positive sign)

$$\begin{cases} i_1 - i_2 = +(i_3 - i_4) \\ i_2 - i_3 = -(i_4 - i_1) \end{cases}$$

or

$$\begin{cases} i_1 - i_2 = -(i_3 - i_4) \\ i_2 - i_3 = +(i_4 - i_1) \end{cases}$$

III.3: (both equations are with negative sign)

$$\begin{cases} i_1 - i_2 = -(i_3 - i_4) \\ i_2 - i_3 = -(i_4 - i_1) \end{cases}$$

Similarly, in III.1 and III.2 the rank of the matrix is 2 and nullity is 2, but under III.3 gives that the rank of the matrix is 1 and nullity is **3**.

Therefore, under Case III, because of the property of i.i.d random variables,

$$\mathbb{E}[X_{i_1 i_2} X_{i_2 i_3}] \mathbb{E}[X_{i_3 i_4} X_{i_4 i_1}] = \mathbb{E}[X_{i_1 i_2}] \mathbb{E}[X_{i_2 i_3}] \mathbb{E}[X_{i_3 i_4}] \mathbb{E}[X_{i_4 i_1}] = 0$$

and

$$\mathbb{E}[X_{i_1 i_2} X_{i_4 i_1}] \mathbb{E}[X_{i_2 i_3} X_{i_3 i_4}] = \mathbb{E}[X_{i_1 i_2}] \mathbb{E}[X_{i_2 i_3}] \mathbb{E}[X_{i_3 i_4}] \mathbb{E}[X_{i_4 i_1}] = 0$$

Then, equation (7) can be expressed as:

$$\begin{aligned}
& \frac{1}{n} \sum_{i_1, \dots, i_4=1}^n \mathbb{E}[X_{i_1 i_2} X_{i_2 i_3}] \mathbb{E}[X_{i_3 i_4} X_{i_4 i_1}] + \mathbb{E}[X_{i_1 i_2} X_{i_3 i_4}] \mathbb{E}[X_{i_2 i_3} X_{i_4 i_1}] \\
& + \mathbb{E}[X_{i_1 i_2} X_{i_4 i_1}] \mathbb{E}[X_{i_2 i_3} X_{i_3 i_4}] \\
& = \frac{1}{n} \cdot \sum_{m=0}^{n-1} \left(0 + \frac{1}{n} \cdot \frac{1}{n} \cdot \mathbb{E}[Y_m^2]^2 \right) \\
& = \frac{1}{n} \cdot \frac{1}{n^2} \cdot \sum_{m=0}^{n-1} \mathbb{E}[Y_m^2]^2 \\
& = \frac{1}{n} \cdot \frac{1}{n^2} \cdot (O(n^3) + O(n^2)) \\
& = 1 + O\left(\frac{1}{n}\right)
\end{aligned} \tag{10}$$

Same as Case II, only under III.3, the nullity of the coefficient matrix is $\mathbf{3}$, which gives $O(n^3)$. As $n \rightarrow \infty$, $O\left(\frac{1}{n}\right) \rightarrow 0$. The leading term is contributed by III.3, under which, both of the coefficient equations are using the negative sign.

Case IV:

$$|i_1 - i_2| = |i_4 - i_1| \neq |i_2 - i_3| = |i_3 - i_4|$$

We change the absolute value into positive and negative cases:

$$i_1 - i_2 = \pm(i_4 - i_1) \neq i_2 - i_3 = \pm(i_3 - i_4)$$

There are three possible subcases as well:

IV.1: (both equations are with positive sign)

$$\begin{cases} i_1 - i_2 = +(i_4 - i_1) \\ i_2 - i_3 = +(i_3 - i_4) \end{cases}$$

IV.2: (one of equations is with positive sign)

$$\begin{cases} i_1 - i_2 = +(i_4 - i_1) \\ i_2 - i_3 = -(i_3 - i_4) \end{cases}$$

or

$$\begin{cases} i_1 - i_2 = -(i_4 - i_1) \\ i_2 - i_3 = +(i_3 - i_4) \end{cases}$$

IV.3: (both equations are with negative sign)

$$\begin{cases} i_1 - i_2 = -(i_4 - i_1) \\ i_2 - i_3 = -(i_3 - i_4) \end{cases}$$

Similarly, in IV.1 and IV.2 the rank of the matrix is 2 and nullity is 2, but under IV.3 gives that the rank of the matrix is 1 and nullity is **3**.

Therefore, under Case IV, because of the property of i.i.d random variables,

$$\mathbb{E}[X_{i_1 i_2} X_{i_2 i_3}] \mathbb{E}[X_{i_3 i_4} X_{i_4 i_1}] = \mathbb{E}[X_{i_1 i_2}] \mathbb{E}[X_{i_2 i_3}] \mathbb{E}[X_{i_3 i_4}] \mathbb{E}[X_{i_4 i_1}] = 0$$

and

$$\mathbb{E}[X_{i_1 i_2} X_{i_3 i_4}] \mathbb{E}[X_{i_2 i_3} X_{i_4 i_1}] = \mathbb{E}[X_{i_1 i_2}] \mathbb{E}[X_{i_2 i_3}] \mathbb{E}[X_{i_3 i_4}] \mathbb{E}[X_{i_4 i_1}] = 0$$

Then, equation (7) can be expressed as:

$$\begin{aligned} & \frac{1}{n} \sum_{i_1, \dots, i_4=1}^n \mathbb{E}[X_{i_1 i_2} X_{i_2 i_3}] \mathbb{E}[X_{i_3 i_4} X_{i_4 i_1}] + \mathbb{E}[X_{i_1 i_2} X_{i_3 i_4}] \mathbb{E}[X_{i_2 i_3} X_{i_4 i_1}] \\ & + \mathbb{E}[X_{i_1 i_2} X_{i_4 i_1}] \mathbb{E}[X_{i_2 i_3} X_{i_3 i_4}] \\ & = \frac{1}{n} \cdot \sum_{m=0}^{n-1} \left(0 + \frac{1}{n} \cdot \frac{1}{n} \cdot \mathbb{E}[Y_m^2]^2 \right) \\ & = \frac{1}{n} \cdot \frac{1}{n^2} \cdot \sum_{m=0}^{n-1} \mathbb{E}[Y_m^2]^2 \\ & = \frac{1}{n} \cdot \frac{1}{n^2} \cdot (O(n^3) + O(n^2)) \\ & = 1 + O\left(\frac{1}{n}\right) \end{aligned} \tag{11}$$

Same as Case II, only under IV.3, the nullity of the coefficient matrix is **3**, which gives $O(n^3)$. As $n \rightarrow \infty$, $O\left(\frac{1}{n}\right) \rightarrow 0$. The leading term is contributed by IV.3, under which, both of the coefficient equations are using the negative sign.

Now, we finish discussing all the cases and sum equation (8), (9), (10), (11) up, then

$$\begin{aligned}
\frac{1}{n} \mathbb{E} \text{Tr}[X^4] &= \frac{1}{n} \sum_{i_1, \dots, i_4=1}^n \mathbb{E}[X_{i_1 i_2} X_{i_2 i_3}] \mathbb{E}[X_{i_3 i_4} X_{i_4 i_1}] + \mathbb{E}[X_{i_1 i_2} X_{i_3 i_4}] \mathbb{E}[X_{i_2 i_3} X_{i_4 i_1}] \\
&\quad + \mathbb{E}[X_{i_1 i_2} X_{i_4 i_1}] \mathbb{E}[X_{i_2 i_3} X_{i_3 i_4}] \\
&= \left(O\left(\frac{1}{n}\right) \right) + \left(1 + O\left(\frac{1}{n}\right) \right) + \left(1 + O\left(\frac{1}{n}\right) \right) + \left(1 + O\left(\frac{1}{n}\right) \right) \\
&= 3 + O\left(\frac{1}{n}\right)
\end{aligned}$$

As $n \rightarrow \infty$, $O\left(\frac{1}{n}\right) \rightarrow 0$. The leading term **3** is contributed by II.3, III.3 and IV.3, under which, both of the coefficient equations are using the negative sign.

3.2 Proof

Proof. Recall the equation:

$$\frac{1}{n} \mathbb{E} \text{Tr}[X^{2k}] = \frac{1}{n} \sum_{i_1, \dots, i_{2k}=1}^n \mathbb{E}[X_{i_1, i_2} X_{i_2, i_3} \dots X_{i_{2k}, i_1}] \quad (12)$$

$$= \frac{1}{n} \sum_{i_1, \dots, i_{2k}=1}^n \sum_{\pi \in \mathcal{P}_2(2k)} \prod_{\{\alpha, \beta\} \in \pi} \mathbb{E}[X_{i_\alpha, i_{\alpha+1}} X_{i_\beta, i_{\beta+1}}] \quad (13)$$

$$= \frac{1}{n} \cdot \frac{1}{n^k} \cdot P(n) \quad (14)$$

$$= \frac{1}{n^{k+1}} \cdot P(n) \quad (15)$$

where $P(n)$ is a polynomial function of n and

$$|i_\alpha - i_{\alpha+1}| = |i_\beta - i_{\beta+1}|$$

We need to find what relation between the indices will give $O(n^{k+1})$ which can be canceled with $\frac{1}{n^{k+1}}$ and contribute to the leading term of the convergence.

Based on the idea in Example 3.1, we separate the relation between indices into several cases.

- All $\{\alpha, \beta\}$ in π satisfy $i_{\alpha+1} = i_\beta$
- Part of the $\{\alpha, \beta\}$ in π satisfy $i_{\alpha+1} = i_\beta$

- All $\{\alpha, \beta\}$ in π satisfy $i_{\alpha+1} \neq i_\beta$

The reason why cases depend on whether $i_{\alpha+1} = i_\beta$ is that the cancellation of the terms in the system of equations might affect the rank of corresponding coefficient matrices.

Case I: All $\{\alpha, \beta\}$ in π satisfy $i_{\alpha+1} = i_\beta$.

We change the absolute value into positive and negative cases as we did in Example 3.1:

$$i_\alpha - i_{\alpha+1} = \pm(i_\beta - i_{\beta+1})$$

I.1: : All of $\{\alpha, \beta\}$ take the positive sign, i.e. $i_\alpha - i_{\alpha+1} = +(i_\beta - i_{\beta+1})$

When all the index equations use positive sign, we have the following matrix equation:

$$\begin{bmatrix} 1 & -2 & 1 & 0 & 0 & \dots & 0 \\ 0 & 0 & 1 & -2 & 1 & \dots & 0 \\ \dots & \dots & \dots & \dots & \dots & \ddots & \dots \\ 1 & 0 & 0 & 0 & 0 & 1 & -2 \end{bmatrix} \begin{bmatrix} i_1 \\ i_2 \\ i_3 \\ \vdots \\ i_{2k-2} \\ i_{2k-1} \\ i_{2k} \end{bmatrix} = \begin{bmatrix} 0 \\ 0 \\ \vdots \\ 0 \end{bmatrix}$$

Now, we have a $k \times 2k$ matrix of coefficients:

$$\begin{bmatrix} 1 & -2 & 1 & 0 & 0 & \dots & 0 \\ 0 & 0 & 1 & -2 & 1 & \dots & 0 \\ \dots & \dots & \dots & \dots & \dots & \ddots & \dots \\ 1 & 0 & 0 & 0 & 0 & 1 & -2 \end{bmatrix}$$

By reducing the matrix, the rank is k , then the nullity is $2k - k = k$.

Then equation (12) can be expressed as:

$$\begin{aligned} \frac{1}{n} \mathbb{E} \text{Tr}[X^{2k}] &= \frac{1}{n} \sum_{i_1, \dots, i_{2k}=1}^n \mathbb{E}[X_{i_1, i_2} X_{i_2, i_3} \dots X_{i_{2k}, i_1}] \\ &= \frac{1}{n} \sum_{i_1, \dots, i_{2k}=1}^n \sum_{\pi \in \mathcal{P}_2(2k)} \prod_{\{\alpha, \beta\} \in \pi} \mathbb{E}[X_{i_\alpha, i_{\alpha+1}} X_{i_\beta, i_{\beta+1}}] \\ &= \frac{1}{n} \cdot \frac{1}{n^k} \cdot O(n^k) \\ &= O\left(\frac{1}{n}\right) \end{aligned} \tag{16}$$

As $n \rightarrow \infty$, the result does not contribute to the leading term.

I.2: : Some equations use positive sign and others use negative sign, i.e $i_\alpha - i_{\alpha+1} = +(i_{\beta+1} - i_\beta)$, $i_\alpha - i_{\alpha+1} = -(i_{\beta+1} - i_\beta)$

Assume the number of negative index equations is j , which means j of k index equations have the form $i_\alpha - i_{\alpha+1} = +(i_{\beta+1} - i_\beta)$ where $i_{\alpha+1} = i_\beta$. The coefficients of indices with this form can be written as a $(k - j) \times 2k$ matrix:

$$\begin{bmatrix} 1 & -2 & 1 & 0 & 0 & \dots & 0 \\ 0 & 0 & 1 & -2 & 1 & \dots & 0 \\ \dots & \dots & \dots & \dots & \dots & \dots & \dots \\ 1 & 0 & 0 & 0 & 0 & 1 & -2 \end{bmatrix}$$

By reducing this matrix, the dimension of null space of this matrix is $k - j$. Then, adding on j free parameters which are canceled by satisfying $i_{\alpha+1} = i_\beta$, the nullity equals to k .

Therefore, we have

$$\frac{1}{n} \mathbb{E} \text{Tr}[X^{2k}] = O\left(\frac{1}{n}\right) \quad (17)$$

which does not contribute to the leading term, either.

I.3: All the signs are negative i.e. $i_\alpha - i_{\alpha+1} = -(i_\beta - i_{\beta+1})$

The number of pairs (α, β) is k , therefore there are k equations of indices. Since $i_{\alpha+1} = i_\beta$, then $i_\alpha = i_{\beta+1}$. There are k free parameters because of $i_{\alpha+1} = i_\beta$. All the i left are all equal to each other, which can be seen as one single free parameter. Therefore, the total number of free parameters is $k + 1$, that is the nullity is $k + 1$.

Then, equation (12) can be re-written as:

$$\begin{aligned} \frac{1}{n} \mathbb{E} \text{Tr}[X^{2k}] &= \frac{1}{n} \sum_{i_1, \dots, i_{2k}=1}^n \mathbb{E}[X_{i_1, i_2} X_{i_2, i_3} \dots X_{i_{2k}, i_1}] \\ &= \frac{1}{n} \sum_{i_1, \dots, i_{2k}=1}^n \sum_{\pi \in \mathcal{P}_2(2k)} \prod_{\{\alpha, \beta\} \in \pi} \mathbb{E}[X_{i_\alpha, i_{\alpha+1}} X_{i_\beta, i_{\beta+1}}] \\ &= \frac{1}{n} \cdot \frac{1}{n^k} \cdot O(n^{k+1}) \\ &= O(1) \end{aligned} \quad (18)$$

Case II: Part of the $\{\alpha, \beta\}$ in π satisfy $i_{\alpha+1} = i_{\beta}$

Under this case, we will discuss three same subcases in Case I.

II.1: : All the signs are positive i.e. $i_{\alpha} - i_{\alpha+1} = +(i_{\beta} - i_{\beta+1})$

Since there is no negative case, no index can be canceled from the equation. Therefore, a $k \times 2k$ coefficient matrix can be derived. After reducing the coefficients' matrix, the rank is still k . We will have

$$\frac{1}{n} \mathbb{E} \text{Tr}[X^{2k}] = O\left(\frac{1}{n}\right) \quad (19)$$

which does not contribute to the leading term of the convergence.

II.2: : Some equations use positive sign and others use negative sign, i.e. $i_{\alpha} - i_{\alpha+1} = +(i_{\beta} - i_{\beta+1})$, $i_{\alpha} - i_{\alpha+1} = -(i_{\beta} - i_{\beta+1})$

Assume there are j pairs of $\{\alpha, \beta\}$ in π satisfy $i_{\alpha+1} = i_{\beta}$. There are three possibilities:

- All of these j pairs satisfy $i_{\alpha} - i_{\alpha+1} = -(i_{\beta} - i_{\beta+1})$
- Some of these j pairs satisfy $i_{\alpha} - i_{\alpha+1} = -(i_{\beta} - i_{\beta+1})$
- None of these j pairs satisfy $i_{\alpha} - i_{\alpha+1} = -(i_{\beta} - i_{\beta+1})$

Under the first possibility, j pairs of terms can be regarded as j free parameters and be canceled out from the equations. The left indices' coefficients construct a $(k - j) \times 2k$ matrix which has $(k - j + 1)$ dimension of null space. Thus, there are $k+1$ free parameters.

Then, we have

$$\frac{1}{n} \mathbb{E} \text{Tr}[X^{2k}] = O(1) \quad (20)$$

Under the left two possibilities, there are less than j free parameters which can be canceled out from the equations, so the nullity of the matrices is less than $k+1$. In other words, we will get

$$\frac{1}{n} \mathbb{E} \text{Tr}[X^{2k}] = O\left(\frac{1}{n}\right) \quad (21)$$

which does not contribute to the leading term under these two possibilities.

II.3: All the signs are negative i.e. $i_{\alpha} - i_{\alpha+1} = -(i_{\beta} - i_{\beta+1})$

Two situations will happen under this case. The first one is although there exist negative equation, there is no cancellation of the indices. This situation is the same as II.1(All the signs are positive i.e. $i_\alpha - i_{\alpha+1} = +(i_\beta - i_{\beta+1})$). Therefore, we have $\frac{1}{n}\mathbb{E}\text{Tr}[X^{2k}] = O\left(\frac{1}{n}\right)$.

The second one is that there exists cancellation of the indices. The indices which are canceled can be regarded as free parameters. There is no pattern of coefficients' matrix, so we check the signs of the indices.

Different from II.2, the signs of the same indices in different equations are not the same. Besides the cancellation caused by the negative situation, no more terms will be canceled. Therefore the rank of the matrix will larger than $2k - k - 1 = k - 1$, which means there are less than $k + 1$ free parameters, so the result of $\frac{1}{n}\mathbb{E}\text{Tr}[X^{2k}]$ cannot contribute to the leading term.

Case III: All (α, β) in π satisfy $i_{\alpha+1} \neq i_\beta$.

III.1: : All the signs are positive i.e. $i_\alpha - i_{\alpha+1} = +(i_\beta - i_{\beta+1})$

III.2: : Some equations use positive sign and others use negative sign, i.e $i_\alpha - i_{\alpha+1} = +(i_{\beta+1} - i_\beta)$, $i_\alpha - i_{\alpha+1} = -(i_{\beta+1} - i_\beta)$

Under both of the III.1 and III.2, the signs before same two indices are not always different. It means that the rank will be bigger than $k - 1$, hence, the nullity is less than $2k - k = k$ and we cannot get equation (19).

III.3: All the signs are negative i.e. $i_\alpha - i_{\alpha+1} = -(i_\beta - i_{\beta+1})$

After moving all the index in the equations to the left hand sides, the signs before same two indices are different, or we can say each $i_\alpha - i_{\alpha+1}$ and $i_{\beta+1} - i_\beta$ equals to each other. It means one row of the $k \times 2k$ coefficients' matrix will have all 0, then the rank of the matrix is $k - 1$. Thus, the number of the free parameters is $k+1$. Then, we have

$$\frac{1}{n}\mathbb{E}\text{Tr}[X^{2k}] = O(1) \tag{22}$$

According to the cases discussed above, we sum equation (16), (17), (18), (19), (20), (21), (22) under each case together. Then,

$$\begin{aligned}
\lim_{n \rightarrow \infty} \frac{1}{n} \mathbb{E} \text{Tr}[X^{2k}] &= \lim_{n \rightarrow \infty} \frac{1}{n} \sum_{i_1, \dots, i_{2k}=1}^n \mathbb{E}[X_{i_1, i_2} X_{i_2, i_3} \dots X_{i_{2k}, i_1}] \\
&= \lim_{n \rightarrow \infty} \frac{1}{n} \sum_{i_1, \dots, i_{2k}=1}^n \sum_{\pi \in \mathcal{P}_2(2k)} \prod_{(\alpha, \beta) \in \pi} \mathbb{E}[X_{i_\alpha, i_{\alpha+1}} X_{i_\beta, i_{\beta+1}}] \\
&= \lim_{n \rightarrow \infty} \frac{1}{n} \cdot \frac{1}{n^k} \cdot (2k-1)!! (n^{k+1} + O(n^k)) \\
&= (2k-1)!! \cdot \lim_{n \rightarrow \infty} \left(1 + O\left(\frac{1}{n}\right)\right) \\
&= (2k-1)!!
\end{aligned}$$

The reason why the answer to this equation is $(2k-1)!!$ is due to Definition 3 – the number of all pairings of $\{1, 2, \dots, 2k\}$ integers, i.e., $\#\mathcal{P}_2(2k) = (2k-1)!!$.

We can see that equation (18), (20), (22) under the negative cases have $O(n^{k+1})$, which finally canceled out with the $\frac{1}{n^{k+1}}$, contributing to the leading term of the results.

□

References

- [1] Kemp, Todd., Math 247A Lecture Notes: *Introduction to Random Matrix Theory* University of California, San Diego. <
<http://www.math.ucsd.edu/~tkemp/247A.Notes.pdf> >
- [2] Kemp, Todd., Zimmermann, David., *Random Matrices with Log-Range Correlations, and Log-Sobolev Inequalities*. Preprints
- [3] Mingo, James A., Speicher, Roland. *Free Probability And Random Matrices*. S.l.: Springer-Verlag New York, 2017. Print
- [4] Wigner, E., *Characteristic Vectors of Bordered Matrices with Infinite Dimensions*. Ann. of Math. 62, 548564 (1955)